

# Type T Pump Operation Manual

for T-1 and T-1-CPF



# Contents

<b>Overview</b> .....	<b>1</b>
Introduction .....	1
Features .....	2
<b>Setup</b> .....	<b>3</b>
Assembly .....	3
<b>Safety Instructions</b> .....	<b>5</b>
Warnings, Cautions, and Notes .....	5
<b>Operation and Maintenance</b> .....	<b>6</b>
Generating Pressure .....	6
Priming .....	7
<b>Connection Diagrams</b> .....	<b>10</b>
T-1 to Jofra Reference Indicator .....	10
T-1-CPF to Crystal Reference Indicator .....	11
<b>Specifications</b> .....	<b>12</b>
<b>Support</b> .....	<b>13</b>
Troubleshooting .....	13
Fitting Kits and Spare Parts .....	16
Appendix A: Assembly Drawings and Parts Lists .....	17
Contact Us .....	20
Returning product to AMETEK .....	20
Warranty .....	20

# Overview

## INTRODUCTION

The Model T-1 is a hand pump mounted on a drip pan with a manifold assembly, capable of producing pressures up to 1000 bar/15 000 psi.

These units are self-contained pressure sources designed to test instruments. They may be used to calibrate pressure gauges or to set hydraulic relief valves and pressure switches. These units produce pressure to test components or systems, and work independently of other pressure sources.

### ► Type T Series Pumps

	Sealing Compound	Medium (Shipped With)
T-1	Buna-N	Water (50/50 mixture of Water and Isopropal Alchohol)
T-1-CPF	Viton®	Oil or Water (Empty)
T-1/VITON	Viton®	Water (50/50 mixture of Water and Isopropal Alchohol)
T-1/EPT	EPT	Water (50/50 mixture of Water and Isopropal Alchohol)
T-1/OIL	Buna-N	Oil (Oil)
T-1/OIL/VITON	Viton®	Oil (Oil)
T-1/OIL/EPT	EPT	Oil (Oil)

## FEATURES

The model Type T pump may be ordered with either oil or a water/alcohol mixture as the pressure medium. There are three available seal packages for the system: Buna-N, Viton®, and EPT.

The Type T pump features a dual pressure port manifold, fine adjust, vent valve, and dual volume control for rapid pressure increase at lower pressures and easier pumping at higher pressures.

### Parts Included with Pump (T-1)

#### ► Reference and Device Under Test Pressure Ports

Part Number	Description
T-134	1/4" NPT Female (swivel)
T-135	1/2" NPT Female (swivel)

### Parts Included with Pump (T-1-CPF)

#### ► Reference and Device Under Test Pressure Ports

Part Number	Description
MPM-15/16-20	CPF Male to 15/16-20 (2)
4715	MP Female to 1/4" Female NPT

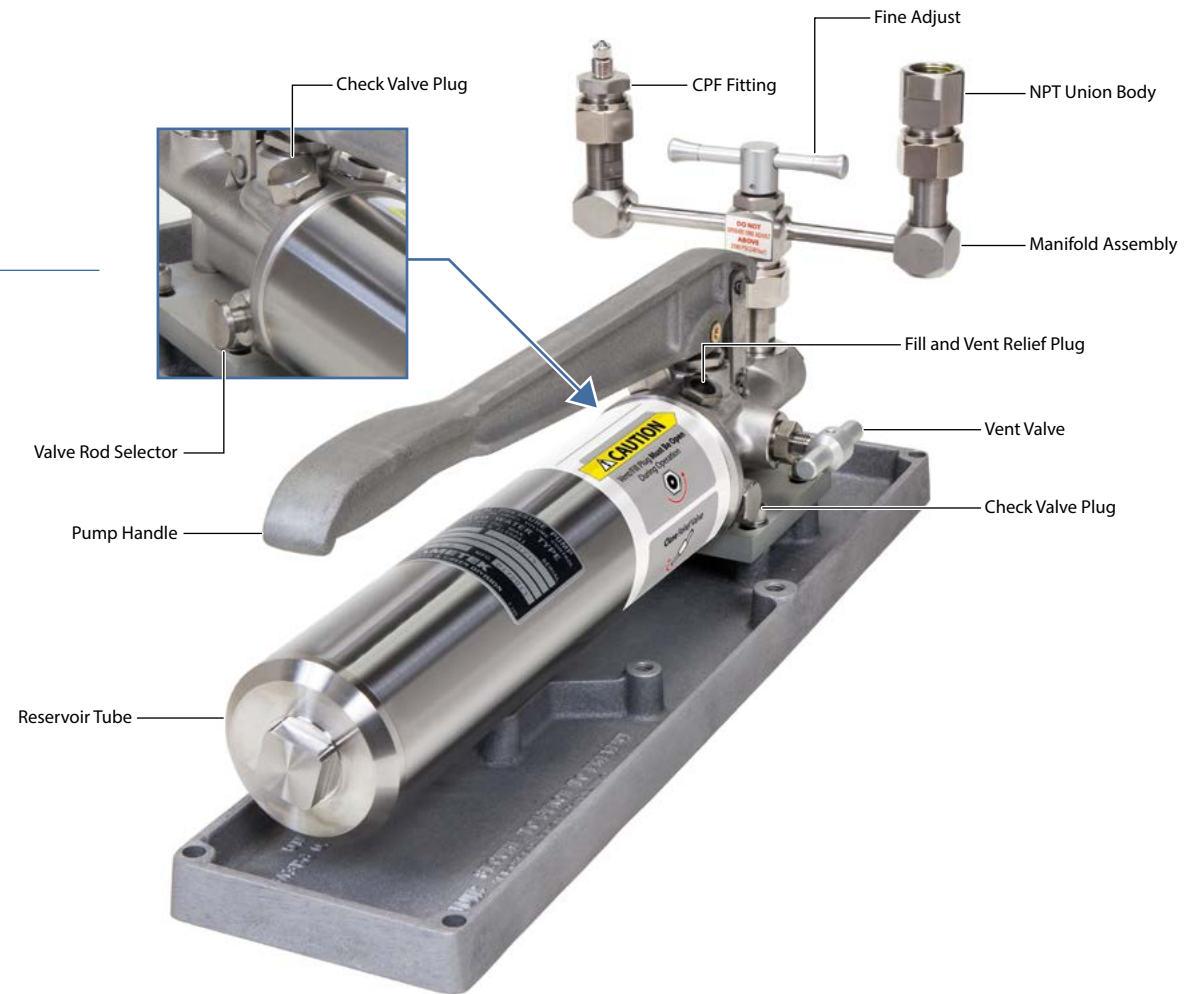

# Setup

## ASSEMBLY

- 1 Open the vent valve.

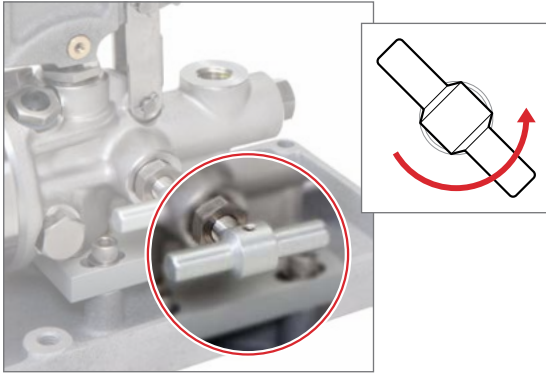

- 2 Attach the pressure manifold to the pump body.



3 Close the vent valve.

**Note:** If using the T-1-CPF, fill with test fluid.

4 Pull the pump handle to the top of its stroke.

5 Pull out the valve rod selector to select the low pressure/high volume setting.

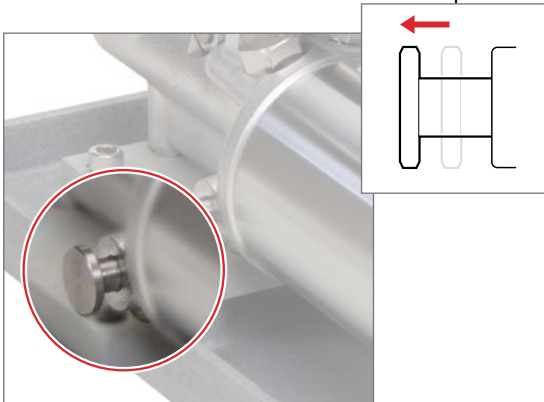

6 Gently operate the pump handle until test fluid fills the top of the pressure ports on the pressure manifold.

**Note:** Lightly tap the column and/or the manifold to make sure that any air bubbles sticking to the walls or in low flow areas are released to float to the surface.

7 Attach the reference instrument to the manifold.

**! CAUTION:** Always choose a reference instrument with a range equal to or greater than the range of the device under test.

8 Attach the device under test to the manifold.

9 Ensure all connections are tight and leak free.

# Safety Instructions

## WARNINGS, CAUTIONS, AND NOTES

---

### **! WARNINGS:**

- Do not connect any external pressure source to this instrument. This unit is designed to test pressure measuring devices connected to the manifold only. Pressure from an external source can result in explosion of the liquid reservoir and possible bodily injury.
- This pump produces pressure up to 15 000 psi. The pressure rating of tubing and fittings used to connect the pump to the test device should exceed 15 000 psi.
- Do not operate above 15 000 psi/1000 bar.

### **! CAUTIONS:**

- To prevent the reservoir from overflowing upon venting, the volume of oil pumped should never exceed the reservoir volume.
- Never operate the pump without fluid in the reservoir. The piston and o-rings require lubrication.
- Do not operate the fine adjust knob above 3500 psi.
- The vent plug must be open to operate this instrument.

**Notes:** All wetted parts are stainless steel, Monel, or Buna-N. Optional o-ring materials are Viton and EPT .

All pumps (except T-1-CPF) ship with either a 50-50 mixture of distilled water and isopropyl alcohol or oil in the reservoir.

# Operation and Maintenance

## GENERATING PRESSURE

**Note:** It may be necessary to prime the pump, particularly if the pump has been inactive for an extended period of time. Refer to [Priming on page 7](#) for instructions on priming the pump.

- 1 Check that the vent fill plug is fully open by turning it counter-clockwise.
- 2 Open the vent valve.

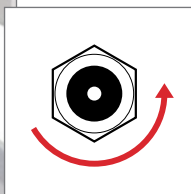
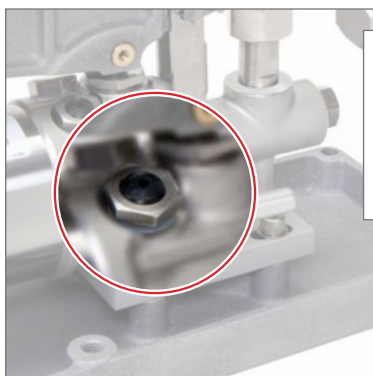

Open the vent plug...

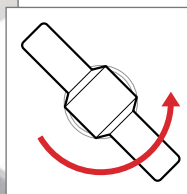

then open the vent valve.

- 3 Set the valve rod selector to control your desired fluid output volume.

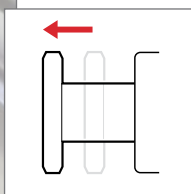

Low Pressure/  
High Volume

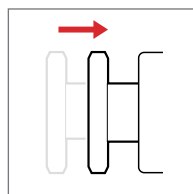

High Pressure/  
Low Volume

**CAUTION:** Only move the valve rod selector while the pump handle is stationary, in the up position.

**Note:** With the valve rod in the “out” position, fluid flow will be at maximum and the maximum achievable pressure will be 1000 psi. To exceed 1000 psi, push the valve rod in.



4 Use best practices to eliminate air pockets from the pressure system.

**Note:** If CPF Fittings are used in your pressure system remaining air can be purged by applying 10 psi or less and loosening the CPF fitting closest to the pressure device. When fluid and air escape from the CPF weep hole, that portion of the system is purged. Repeat this process for each pressure device in the pressure system which is connected to a CPF fitting.

5 Verify that the reference gauge and the device under test are indicating pressure.

6 Operate the pump handle to achieve a system pressure close to, but less than, your desired target pressure.

7 Pull the pump handle to the top of its stroke.

8 Push in the valve rod selector to select the high pressure/low volume setting.

9 Wait for the pressure to stabilize.

10 Carefully push down the pump handle to achieve the target pressure.

**Note:** Below 3500 psi, you may also use the fine adjust knob for small pressure adjustments.

## PRIMING

All pumps are thoroughly tested at the factory before shipment. One of the most common difficulties encountered is the loss of prime, which is evidenced by an inability to build pressure. This is caused by entrapped air in the reservoir, which may collect in the high pressure/low volume check valve. When this occurs, the pump will not develop pressure with the valve rod selector positioned in, to the high pressure/low volume setting. The following priming procedure will correct the condition.

**Note:** For priming purposes, *pump vigorously* with full strokes of the hand lever.

**Note:** Verify the pump reservoir has sufficient fluid.

### ► To Prime the Pump

1 Connect a reference indicator with a pressure range of at least 5000 psi to the manifold.

2 Plug the remaining port of the manifold.



- 3 Pull the pump handle to the top of its stroke.
- 4 Open the vent valve.
- 5 Pull out the valve rod selector to select low pressure/high volume.

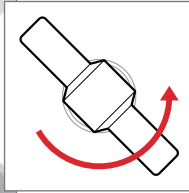
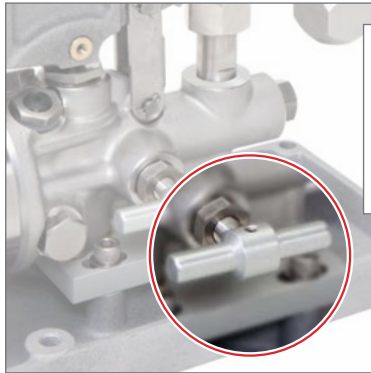

Open the vent valve...

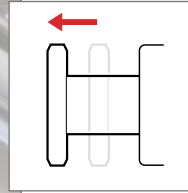

then select low pressure/high volume.

- 6 Pump ten full strokes.
- 7 Close the vent valve
- 8 Continue pumping to verify the low pressure/high volume setting operates properly and that the pump holds pressure.
- 9 Open the vent valve.
- 10 Pump ten more strokes.
- 11 Remove the high pressure/low volume check valve plug.

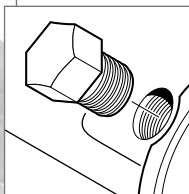
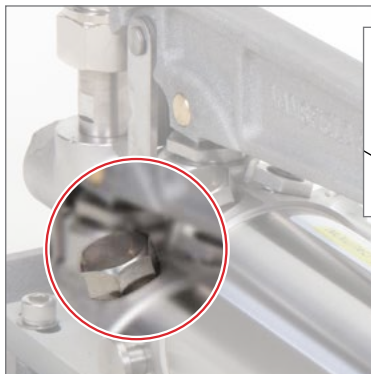

- 12 Slowly pump two and one-half strokes, positioning the pump lever at approximately 45 degrees, halfway through its stroke.

- 13 Allow system fluid to flow out of the high pressure check valve, flushing entrapped air.
- 14 Examine the port for air bubbles which may adhere to the threads or parts.  
**Note:** If air bubbles are present, repeat steps 12 through 14 until no more air bubbles appear.
- 15 Replace the high pressure/low volume check valve plug and tighten partially.
- 16 Use slight pressure on the hand lever to push system fluid past the high pressure/low volume check valve plug to ensure complete purging of the valve port.
- 17 Tighten the high pressure/low volume check valve plug.
- 18 Operate the pump handle until pumping becomes difficult.
- 19 Raise the pump handle.
- 20 Push in the valve rod selector to the high pressure/low volume position.

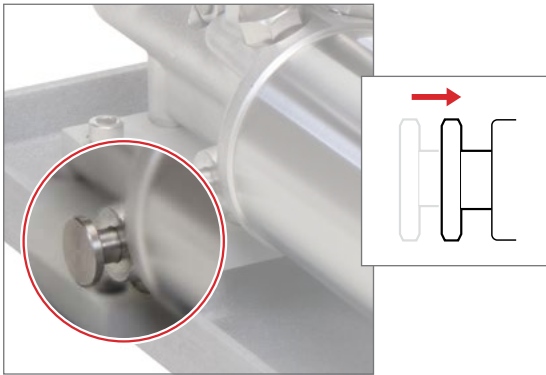

- 21 Resume pumping to verify the pump is operating properly.

**Note:** If the high pressure/low volume setting does not operate properly, there is more air trapped in the high pressure/low volume check valve. The priming procedure must be repeated.

# Connection Diagrams

## T-1 TO JOFRA REFERENCE INDICATOR

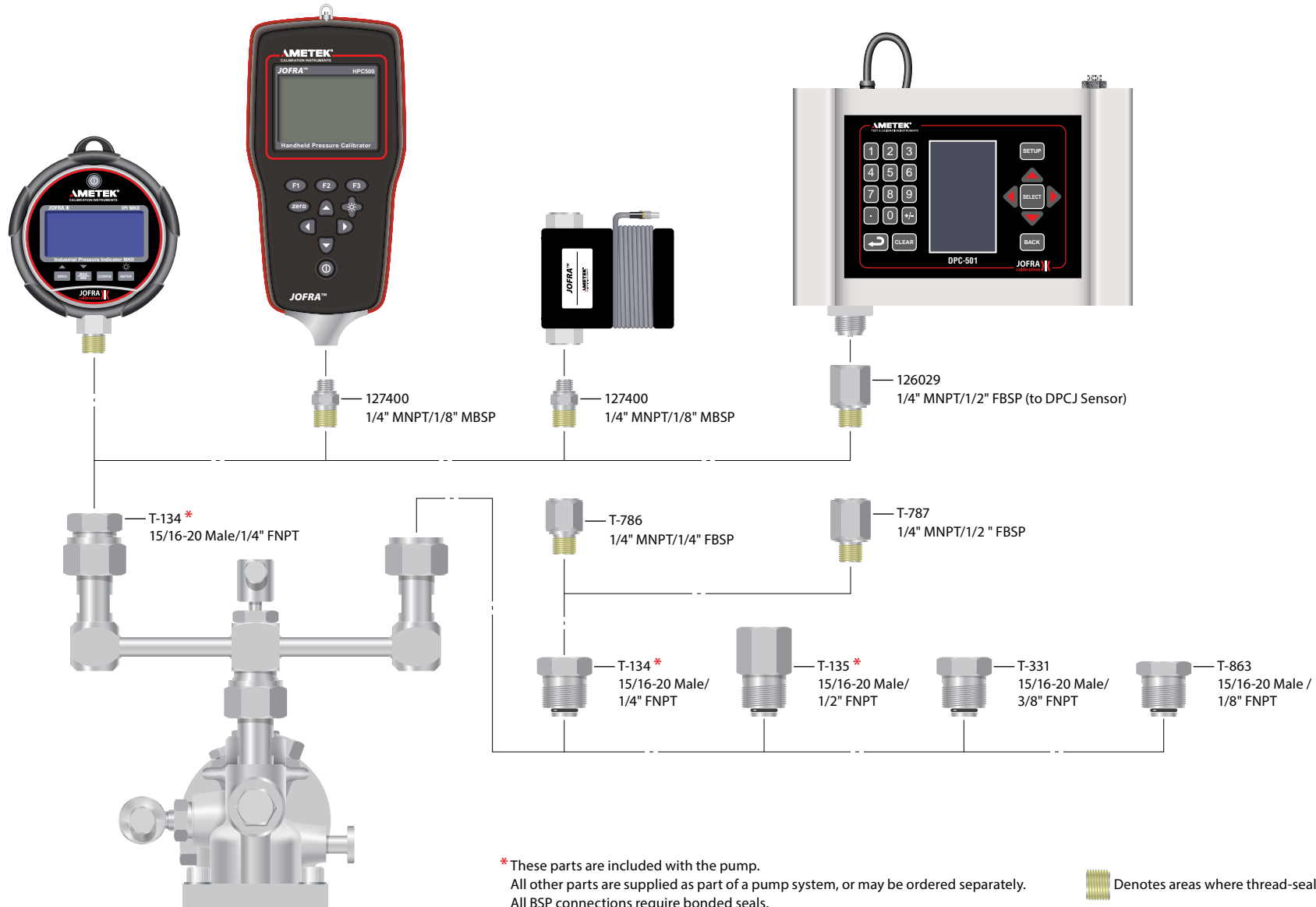

# T-1-CPF TO CRYSTAL REFERENCE INDICATOR

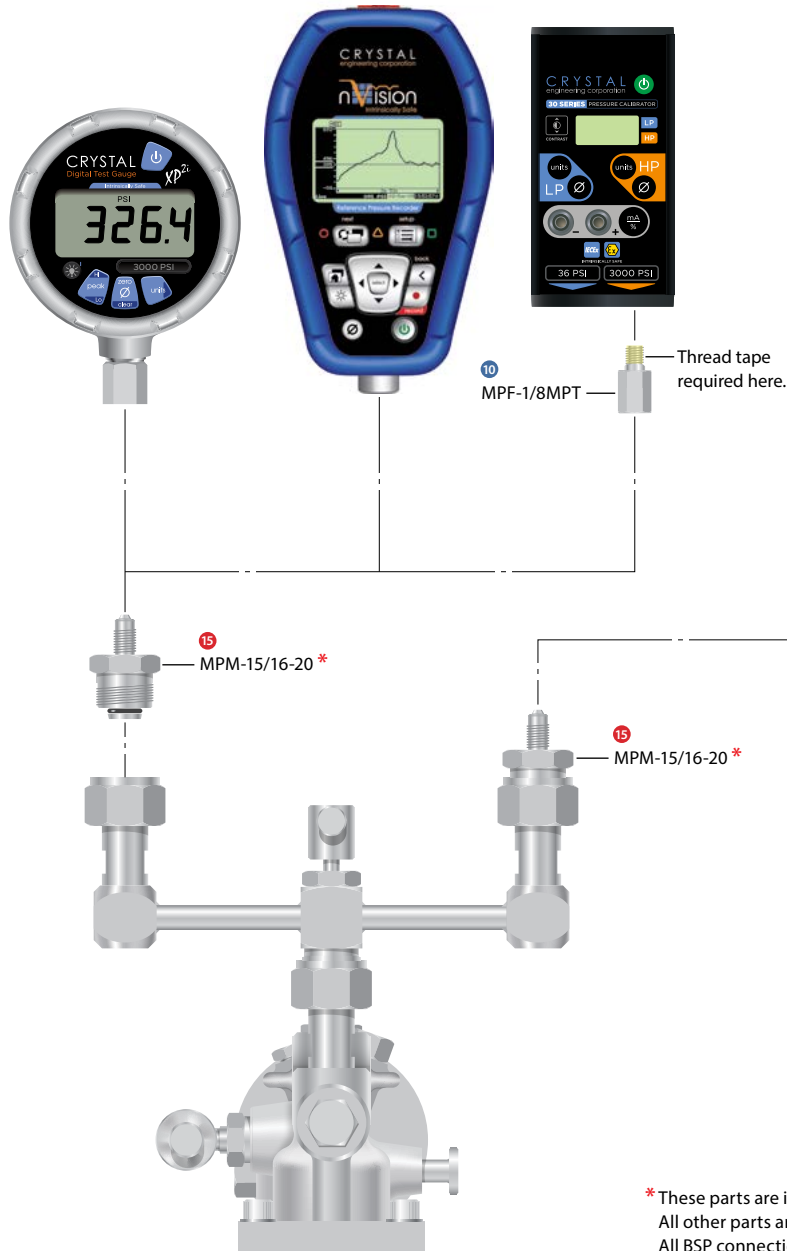

## ► CPF Fittings

### NPT MALE

MPF-1/8QTM	1/8" Quick Test NPT Male	10
MPF-1/8MPT	1/8" NPT Male	10
MPF-1/4QTM	1/4" Quick Test NPT Male	10
MPF-1/4MPT	1/4" NPT Male	10

Additional NPT sizes available in non-CPF MP adapters

### NPT FEMALE

MPF-1/8QTF	1/8" Quick Test NPT Female	10
MPF-1/4QTF	1/4" Quick Test NPT Female	10
MPF-1/4FPT	1/4" NPT Female	10
MPF-1/2QTF	1/2" Quick Test NPT Female	5

Additional NPT sizes available in non-CPF MP adapters

### BSP

MPF-1/8BSPF	G 1/8" Female	10
MPF-1/4BSPF	G 1/4" Female	10
MPF-3/8BSPF	G 3/8" Female	10
MPF-1/2BSPF	G 1/2" Female	10

### TRANSMITTER

MPF-5/16TRM	for Foxboro, Rosemount, & Yokogawa	5
MPF-1/4TRM	for Honeywell	5

### TUBE

MPF-1/4TBM	1/4" Tube Male	5
MPF-3/8TBM	3/8" Tube Male	5
MPF-1/2TBM	1/2" Tube Male	5

### CPF

MPF-MPF	Female to Female	10
MPF-MPFTU	T-Union (Female)	10
MPF-MPFBULK	Bulkhead (Female to Female)	10
MPF-CAP	Cap	10

### ADDITIONAL

MPF-M20QTF	M20 x 1.5 Quick Test Female	5
MPF-M20X1.5F	M20 x 1.5 Female	10
MPF-QCN	Quick-Connect Nut	5
MPF-AN4M	AN4 Male	5

## ► Non-CPF MP Fittings

### Medium Pressure FEMALE to NPT FEMALE

4501	1/8 NPT	15
4715 *	1/4 NPT	15
4502	3/8 NPT	15
4503	1/2 NPT	15

### Medium Pressure FEMALE to NPT MALE

4714	1/4 NPT	15
4494	3/8 NPT	15
4495	1/2 NPT	15
4496	3/4 NPT	10

### Medium Pressure MALE to NPT FEMALE

4497	1/8 NPT	15
4498	1/4 NPT	15
4499	3/8 NPT	15
4500	1/2 NPT	15

### Medium Pressure MALE to NPT MALE

4698	1/4 NPT	15
4492	3/8 NPT	15
4493	1/2 NPT	15

5 300 bar/5000 psi

10 700 bar/10000 psi

15 1000 bar/15000 psi

(Non-CPF MP adapters require wrench tightening.)

\* These parts are included with the pump.  
 All other parts are supplied as part of a pump system, or may be ordered separately.  
 All BSP connections require bonded seals.

# Specifications

## Pressure Ranges

T-1 and T-1-CPF ..... 0 to 1000 bar / 0 to 15 000 psi

---

## Recommended Test Fluids

The following fluids are recommended for use with this pump:

Standard ..... Distilled water or Isopropyl alcohol

Optional ..... MGAAA oil

Other fluids compatible with stainless steel, Monel, Buna N and Teflon may be used. Optional Viton and EPT o-rings are available.

---

## Pressure Connections

### ► Reference Port

T-1 ..... 1/4" FNPT or 1/2" FNPT

T-1-CPF ..... CPF Male

### ► Device Under Test Port

T-1 ..... 1/4" FNPT or 1/2" FNPT

T-1-CPF ..... 1/4" Female NPT

---

## Dimensions

Pump ..... 224 (L) x 127 (W) x 217 (H)\* mm.

Weight ..... 18.6 lbs / 8.4 kg

\* Height includes manifold.

# Support

## TROUBLESHOOTING

### Failure to Pump

- ▶ **Problem:** The pump fails to develop pressure when the hand lever is operated.
- ▶ **Solution:** Verify that the vent valve is closed and that there is sufficient fluid in the reservoir. If necessary, add fluid through the fill plug and follow the Pump Priming Procedure.

If the failure continues, one or both of the check valves may be leaking. Use the following procedure to replace both the high pressure and low pressure o-rings.

#### ▶ To Replace the Check Valve O-rings

- 1 Raise the pump handle to the top of its stroke.
- 2 Position the valve rod selector for the o-ring you wish to replace.
  - (a) Pull out the valve rod selector to select the low pressure/high volume setting.
  - (b) Push in the valve rod selector to select the high pressure/low volume setting.
- 3 Remove the check valve plug you wish to replace.
- 4 Replace the o-ring located on the check valve plug.

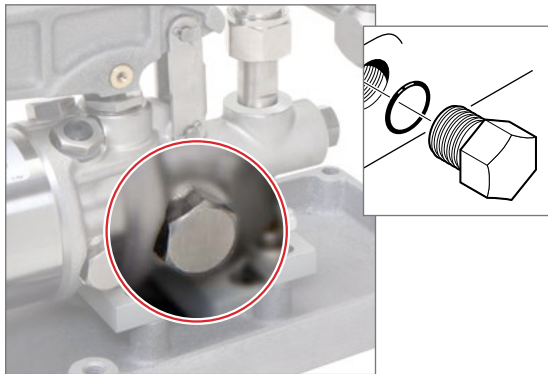

Low pressure/high volume check valve plug o-ring.

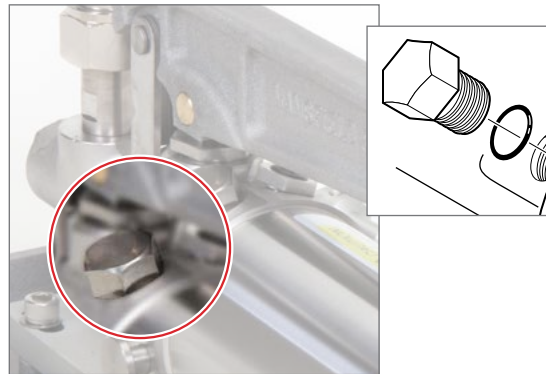

High pressure/low volume check valve plug o-ring.

- 5 Slowly pump two and one-half strokes, positioning the pump lever at approximately 45 degrees, halfway through its stroke.
- 6 Allow system fluid to flow out of the low pressure check valve, flushing entrapped air.

**7** Examine the port for air bubbles which may adhere to the threads or parts.

**Note:** If air bubbles are present, repeat steps 2 through 4 until no more air bubbles appear.

**8** Replace the check valve plug and tighten partially.

**9** **If replacing the low pressure/high volume check valve plug...** Tighten the check valve plug.

The procedure for the low-pressure/high volume side is now complete.

**10** **If replacing the high pressure/low volume check valve plug...** Use slight pressure on the hand lever to push system fluid past the high pressure/low volume check valve plug to ensure complete purging of the valve port.

**11** Tighten the high pressure/low volume check valve plug.

**12** Operate the pump handle until pumping becomes difficult.

**13** Raise the pump handle to the top of its stroke.

**14** Push in the valve rod selector to the high pressure/low volume position.

**15** Resume pumping to verify the pump is operating properly.

---

## Pump Does Not Hold Pressure

► **Problem:** The pump operates but the pressure declines beyond normal thermodynamic effects.

► **Solution:** One of two o-rings may be leaking.

As the pressure drops, observe the hand lever. If the hand lever rises, the discharge check valve is leaking and its o-ring should be replaced.



► **To Replace the Discharge Check Valve O-ring**

- 1 Remove the plug and O-Ring from the front of the pump body.
- 2 Replace the O-ring at the base of the plug.
- 3 Replace the plug.

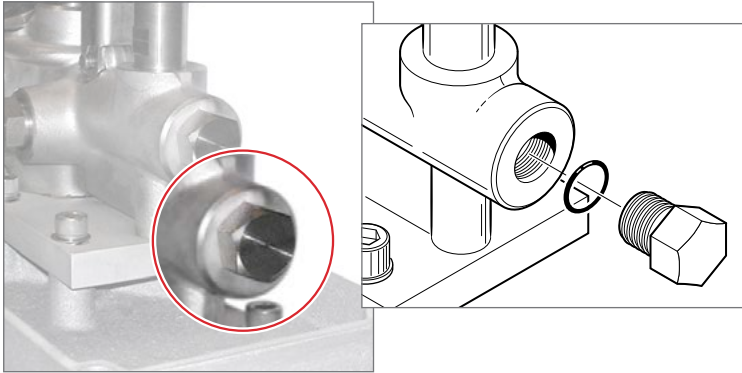

Replacing the discharge check valve o-ring.

► **To Replace the Vent Valve O-ring**

- 1 Apply a wrench to the nut at the base of the pressure relief valve.
- 2 Remove the vent valve.
- 3 Replace the O-ring at the base of the valve.
- 4 Install the valve.

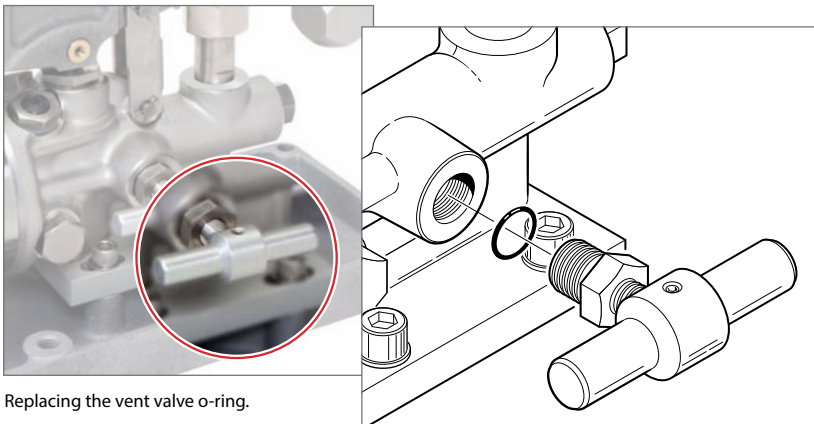

Replacing the vent valve o-ring.

## FITTING KITS AND SPARE PARTS

---

### Service Kits

- ▶ T-1  
T-250..... Buna N rebuild kit
- T-559..... Viton rebuild kit
- T-326..... EPT rebuild kit

- ▶ T-1-CPF  
T-559..... Viton rebuild kit

### Hoses

- ▶ T-1  
KH-18 .....Hose. 0.46 m 1/4" NPT male x 1/4" NPT male 700 bar / 10 000 psi.

- ▶ T-1-CPF  
MPH15K-1..... 1 meter CPF hose

### Adapters

- ▶ T-1  
T-134.....Union Body. 15/16-20 UNEF male x 1/4" NPT female.
- T-135.....Union Body. 15/16-20 UNEF male x 1/2" NPT female.
- T-186.....Union Body. 15/16-20 UNEF male x 7/16" NPT female.
- T-331.....Union Body. 15/16-20 UNEF male x 3/8" NPT female.
- T-863.....Union Body. 15/16-20 UNEF male x 1/8" NPT female.
- T-786.....Adapter. 1/4" NPT male x 1/4" BSP female.
- T-787.....Adapter. 1/4" NPT male x 1/2" BSP female.
- T-915.....Quick Connector. 1/4" NPT male.
- T-916.....Quick Connector Plug. 1/4" NPT male.

- ▶ T-1-CPF  
Refer to the [connection diagram on page 11](#) for a complete list of adapters.

**APPENDIX A: ASSEMBLY DRAWINGS AND PARTS LISTS**

► Figure 1 • Hydraulic Hand Pump Type T Assembly

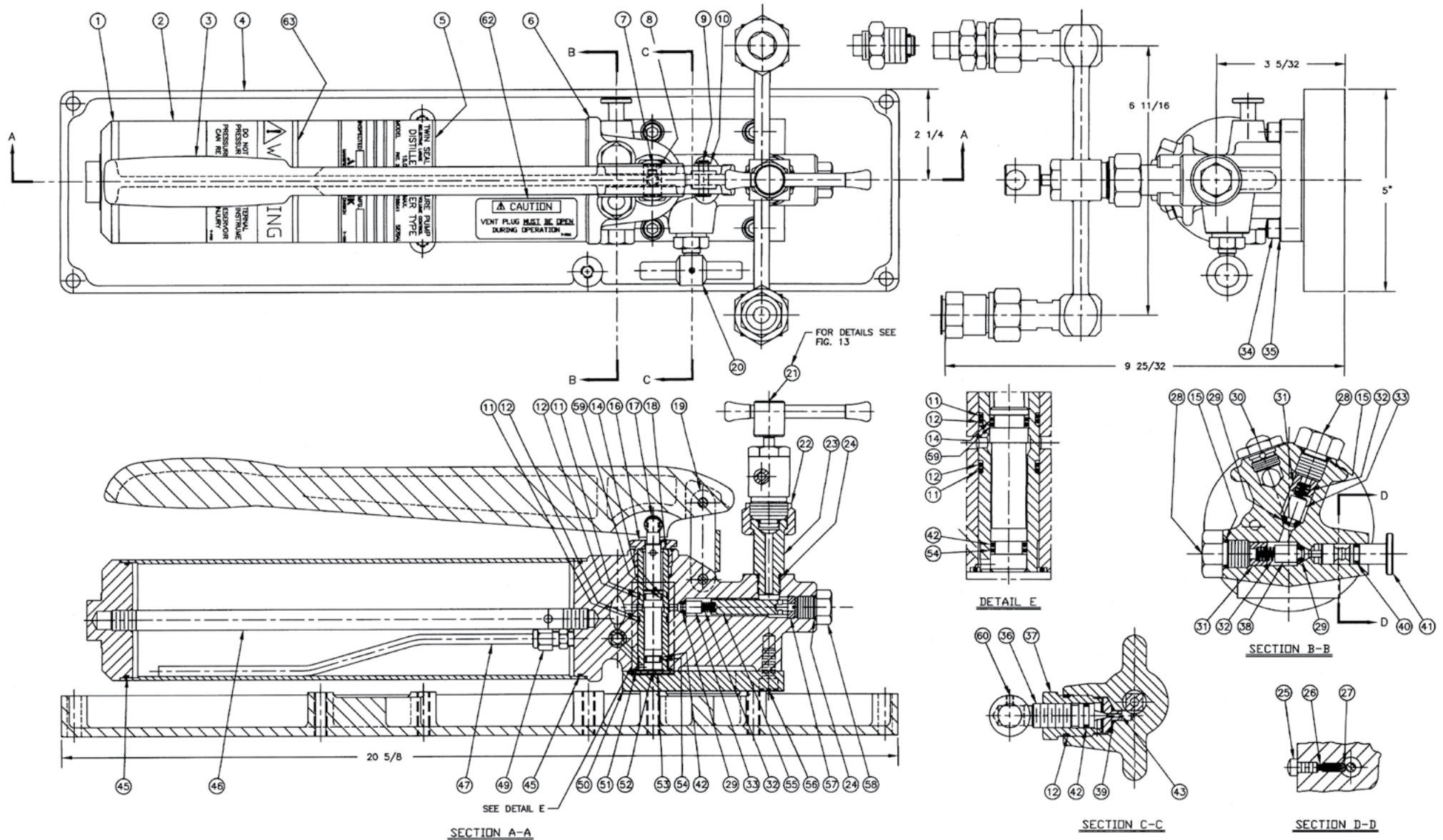

► Figure 1 • Hydraulic Hand Pump Type T Assembly Parts List

ITEM NUMBER	PART NUMBER	UNITS PER DESCRIPTION	ASSEMBLY
1	T-328	CAP, Reservoir .....	1
2	T-131	TUBE, Reservoir .....	1
3	T-165	HANDLE, Pump .....	1
4	T-118	DRIP PAN .....	1
5	T-199	PLATE, Pump identification .....	1
6	T-120	BODY, Pump .....	1
7	T-160	SCREW, Piston pin .....	1
8	T-161	SHOE, Piston pin .....	1
9	T-142	PIN, Clevis .....	2
10	T-144	HAIR PIN, Cotter .....	2
11	10-90020	BACK-UP RING, Cylinder (T-112) .....	2
12	10-90013	"O" RING (T-153) .....	3
13	T-102	HANDLE KNOB, Relief valve .....	1
14	10-90019	BACK-UP RING, Piston (T-158) .....	1
15	10-90027	"O" RING (T-154) .....	2
16	T-108	PLUG, Cylinder retaining .....	1
17	T-145	PIN, Piston .....	1
18	T-236	CYLINDER, Pump .....	1
19	T-143	CLEVIS .....	1
20	T-773	HANDLE, Relief valve .....	1
21	T-149	MANIFOLD ASS'Y (For components see pg. 16) .....	1
22	T-146	NUT, Union .....	1
23	T-126	NIPPLE, Union .....	1
24	10-90009	"O" RING (T-136) .....	2
25	T-166	SCREW .....	2
26	T-116	SPRING, Valve rod .....	1
27	T-133	DETENT PIN, Valve Rod .....	1
28	T-117	PLUG, Pump body .....	2
29	10-90001	"O" RING (T-152) .....	3
30	IGT-302	PLUG, Fill and Vent Relief Assembly .....	1
31	T-127	SPACER, Check valve .....	2
32	CV-1-5	SPRING, Check valve .....	3
33	T-147	POPPET, High pressure valve .....	2
34	01-90007	SCREW, Drip pan attaching .....	4
35	T-167	WASHER, Drip pan attaching .....	4
36	T-110	STEM, Relief valve .....	1
37	T-109	BODY, Relief valve .....	1
38	T-194	POPPET, Valve .....	1
39	10-90002	"O" RING, Relief valve (T-175) .....	1

ITEM NUMBER	PART NUMBER	DESCRIPTION	UNITS PER ASSEMBLY
40	10-90004	"O" RING, Valve rod (T-155) .....	1
41	T-115	VALVE ROD .....	1
42	10-90005	"O" RING (T-151) .....	2
43	T-111	SEAT, Relief valve .....	1
45	10-90010	"O" RING, Reservoir tube (T-156) .....	2
46	T-130	STUD, Reservoir .....	1
47	T-140	TUBE, Inlet .....	1
49	12-90152	FITTING, Inlet tube .....	1
50	T-408	PLATE, Body .....	1
51	10-90012	"O" RING, Cylinder (T-164) .....	1
52	T-106	PISTON .....	1
53	T-595	LINER, Body Plate .....	1
54	10-90018	BACK-UP RING, Piston (T-159) .....	1
55	T-107	GUIDE ROD .....	1
56	01-90004	SCREW, Body attaching .....	3
57	T-141	PLUG, Retaining .....	1
58	T-103	PLUG .....	1
59	10-90006	"O" RING (T-154) .....	1
60	108-114	SCREW .....	1
61	01-90058	SCREW .....	1
62	T-754	CAUTION LABEL .....	1
63	T-755	WARNING LABEL .....	1

► Figure 2 • Manifold Assembly and Parts List

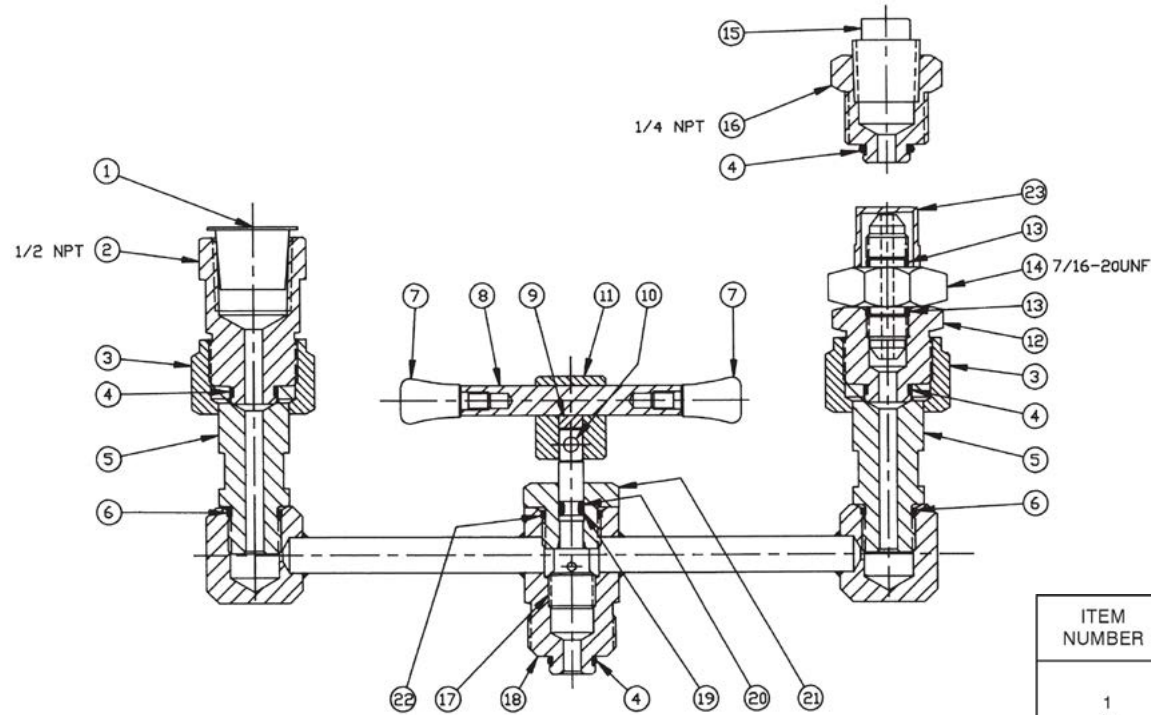

ITEM NUMBER	PART NUMBER	DESCRIPTION	UNITS PER ASSEMBLY
	T-149	ASSEMBLY, TYPE "T" MANIFOLD .....	—
1		THREAD PROTECTOR ½ NPT .....	1
2	T-135	BODY, Union - ½ NPT .....	1
3	T-146	NUT, Union .....	2
4	10-90027	"O" RING (T-154) .....	3
5	T-126	NIPPLE, Union .....	2
6	10-90009	"O" RING, Union nipple (T-136) .....	2
7	T-102	KNOB, Handle .....	2
8	T-119	HANDLE, Vernier .....	1
9	T-190	PLUG, Friction .....	1
10	T-174	SCREW, Hub .....	1
11	T-132	HANDLE HUB, Vernier .....	1
12	T-186	BODY, Union - 7/16 - 20 UNF .....	1
13	10-90005	"O" RING, Nipple (T-151) .....	2
14	T-185	NIPPLE, 7/16 - 20 UNF .....	1
15	T-162	PLUG, Pipe .....	1
16	T-134	BODY, Union - ¼ NPT .....	1
17	T-114	PISTON, Vernier .....	1
18	T-125	MANIFOLD, Offset pipe .....	1
19	10-90001	"O" RING, Vernier (T-152) .....	1
20	10-90017	BACK UP RING, Vernier (T-179) .....	1
21	T-113	BUSHING, Vernier piston .....	1
22	10-90011	"O" RING, Vernier (T-157) .....	1
23	99-90001	CAP .....	1

## CONTACT US

### United Kingdom

Tel +44 (0)1243 833 302

[jofra@ametek.co.uk](mailto:jofra@ametek.co.uk)

### France

Tel +33 (0)1 30 68 89 40

[general.lloyd-instruments@ametek.fr](mailto:general.lloyd-instruments@ametek.fr)

### Germany

Tel +49 (0)2159 9136 510

[info.mct-de@ametek.de](mailto:info.mct-de@ametek.de)

### Denmark

Tel +45 4816 8000

[jofra@ametek.com](mailto:jofra@ametek.com)

### USA

*Florida - Mansfield & Green*

Tel +1 (800) 527 9999

[cal.info@ametek.com](mailto:cal.info@ametek.com)

*California - Crystal Engineering*

Tel +1 (800) 444 1850

[sales@crystalengineering.net](mailto:sales@crystalengineering.net)

### India

Tel +91 22 2836 4750

[jofra@ametek.com](mailto:jofra@ametek.com)

### Singapore

Tel +65 6484 2388

[jofra@ametek.com](mailto:jofra@ametek.com)

### China

*Shanghai*

Tel +86 21 5868 5111

*Beijing*

Tel +86 10 8526 2111

*Guangzhou*

Tel +86 20 8363 4768

[jofra.sales@ametek.com.cn](mailto:jofra.sales@ametek.com.cn)

## RETURNING PRODUCT TO AMETEK

Please contact your sales representative to complete a Return Material Authorization (RMA) form and/or receive an RMA number.

Return/shipping instructions will be provided with the RMA number.

## WARRANTY

This instrument is warranted against defects in workmanship, material and design for one (1) year from date of delivery to the extent that AMETEK will, at its sole option, repair or replace the instrument or any part thereof which is defective, provided, however, that this warranty shall not apply to instruments subjected to tampering or, abuse, or exposed to highly corrosive conditions.

THIS WARRANTY IS IN LIEU OF ALL OTHER WARRANTIES WHETHER EXPRESS OR IMPLIED AND AMETEK HEREBY DISCLAIMS ALL OTHER WARRANTIES, INCLUDING, WITHOUT LIMITATION, ANY WARRANTY OF FITNESS FOR A PARTICULAR PURPOSE OR MERCHANTABILITY. AMETEK SHALL NOT BE LIABLE FOR ANY INCIDENTAL OR CONSEQUENTIAL DAMAGES, INCLUDING, BUT NOT LIMITED TO, ANY ANTICIPATED OR LOST PROFITS.

This warranty is voidable if the purchaser fails to follow any and all instructions, warnings or cautions in the instrument's Instruction Manual.

If a manufacturing defect is found, AMETEK will replace or repair the instrument or replace any defective part thereof without charge; however, AMETEK's obligation hereunder does not include the cost of transportation, which must be borne by the customer. AMETEK assumes no responsibility for damage in transit, and any claims for such damage should be presented to the carrier by the purchaser.



---

© 2013 AMETEK Incorporated  
8600 Somerset Drive, Largo, Florida 33773